

HKD[®]

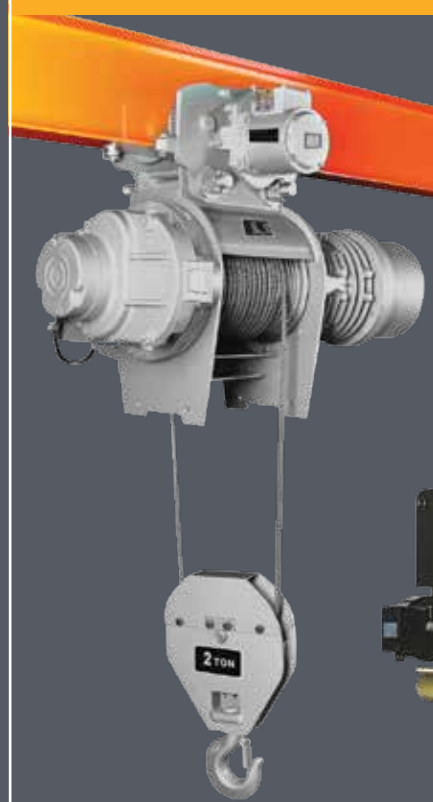

ELECTRIC WIRE ROPE HOIST



HKD PRODUCTS SDN BHD
www.hkdproducts.com

ELECTRIC WIRE ROPE HOIST

PRODUCT ADVANTAGES

- ▶ MODULE COMBINATION, COMPACT STRUCTURE
- ▶ PRECISE POSITIONING, FAST HANDLING
- ▶ QUIET OPERATION, ENERGY SAVING
- ▶ CLASSIC AND DURABLE, SAFE AND RELIABLE



PRODUCT CONFIGURATION

- ▶ TROLLEY WITH FREQUENCY CONVERSION MOTOR
- ▶ DOUBLE SPEED/FREQUENCY CONVERSION LIFTING MOTOR
- ▶ MOTOR PROTECTION GRADE IP55, INSULATION GRADE F
- ▶ ELECTROMAGNETIC DISC BRAKE, MAINTENANCE-FREE
- ▶ CONTROL VOLTAGE 24V/36V/48V/110V
- ▶ SCHNEIDER CONTACTOR & INVERTER
- ▶ 380V/415V/440V/460V/3Ph/50Hz
- ▶ LIFTING LIMIT SWITCH
- ▶ HOOK, WITH SAFETY LATCH
- ▶ OVERLOAD LIMITER
- ▶ AMBIENT TEMPERATURE: -20°C~+40°C
- ▶ MOTOR OVER TEMPERATURE PROTECTION

Compact structure, light weight, low wheel pressure, high comprehensive cost performance

The performance of the leading technical components of HKD guarantees the optimal extreme dimension and equipment height of the product, and the structure is compact under the premise of ensuring high performance. In the same plant and work area, electric wire rope hoist can cover a larger working range, increasing the utilization of the internal area of the large plant reduces the dead zone. If the design is based on HKD product series parameters during the design stage of the plant, the requirements for the height and bearing capacity of the lifting equipment can be greatly reduced, and the investment of the plant can be reduced by more than 10% to improve the investment efficiency.

Selection of high quality of components with safety and reliability and durable in use

Components with high quality are the basis for excellent quality of products. HKD company takes each components seriously from lifting motors to reducers, from reels to steel wire ropes, from safe and reliable electrical components to the best structure components. Because HKD company believes the only each components of good performance and quality of the complete machine. Lifting trinity mechanism with compact structure and superior performance is developed and designed for HKDE series European Electric Wire Rope Hoist. The reduction gear products low noise and becomes durable in use by high precision grinding and hardening treatment of the gear surface.

Electrical connection sustained rate is up to 60% of the lifting motor, which not only meets frequent use during the process of production, but improves the reliability of the products. The imported brake disc provides the breaking lifetime of more than one million times with excellent wear-resisting property.

Precise positioning, efficient operation, and improved production efficiency

Double speed (optional frequency conversion) and frequency conversion control of trolley ensure the efficient running of the crane and promotion of logistics efficiency in workshop, and ensure the implementation of the whole work plans of customers on schedule. By the application of frequency conversion technology, it can effectively reduce shaking of load in the process of handling, which makes the load positioning more quickly and accurately. Simultaneously, it significantly reduces the impact of starting and braking, thus the whole handling process becomes much more smooth and safe.

Saving operating costs, green energy saving

European-style cranes equipped with HKD electric wire rope series hoist can significantly reduce the weight of the main beam and the whole machine and reduce the total operating power.

Plants that also use traditional domestic cranes save an average of more than 30% of electricity per year. At the same time, Kaidao electric wire rope hoist runs with excellent noise in the national standard, create a quieter working space.

Modular design, multiple options, to meet various demands of customer

The concept of modular design has always been throughout the whole product design, which ensures the standard and interchangeability of parts, greatly reduces the maintenance costs of products. All product series is provided with complete inventory of spare parts, and professional service team ensures to provide after-sales service to solve the troubles of customers after purchasing the equipment in a timely manner.

Modular design, flexible combination, Meet the individual needs of customers



Lifting drive unit

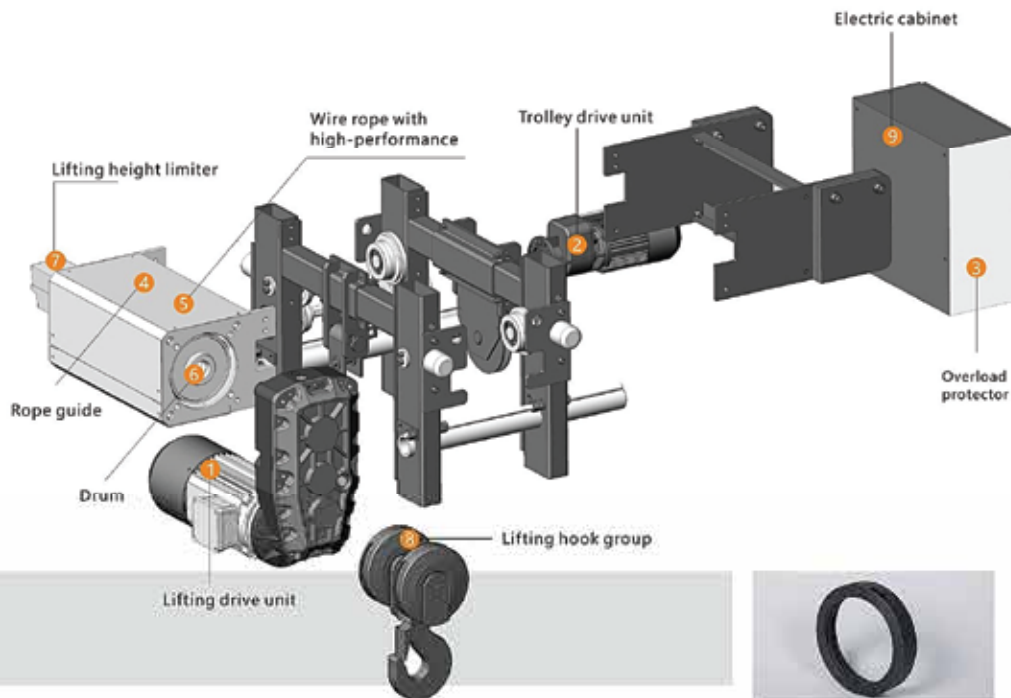

High-performance, large driving force and compact structure
Various components are running efficiency
Low energy consumption, low noise and eco-friendly design
Smooth running, low impact, safe and reliable
No-wear design, long service life
Electrical connection sustained rate is up to 60% to meet the demands of the high frequency lifting
Service life to asbestos-free brake can up to one million times
High protection grade of brake can meet the requirements of severe environment



Trolley drive unit

Trinity of high-performance motor, reduction gearbox and brake. Compact structure, excellent performance.
Low energy consumption, low noise and eco-friendly design. Variable frequency control, smooth running, low impact and meeting requirements of a variety of speed.
Asbestos-free brake disc and its normal service life can be up to one million times. No-wear design.
Maintenance-free, long servicelife.



Rope guide

Light weight, good wear resistance, to reduce the wear of wire rope effectively.
Prevent wire rope from skipping and loosening to off-groove and safety first.



Overload protector

After the rated weight, the lifting loop of hoist can be cut off quickly, so that the hoist can not lift heavy objects, so as to protect the hoist and operators' safety



Drum

Use the Q345 type seamless steel tube as raw material and process it by numbers of working procedure.
Advanced processing methods to ensure concentricity of the drum. The depth of rope groove is in compliance with the FEM standard. High-strength pressing plates and bolts are fastened on the end of the wire rope to ensure the safety of lifting.



Electric cabinet

Rational design, convenient maintenance, decreasing running cost. Professional and high quality of electrical components, safe and reliable. Multiple safety protection devices to ensure equipment safe. Protection grade IP55. Clear identification to easy for trouble removal.



Lifting hook group

DIN standard of lifting hook with safety latch.
Forged by the high-strength material of T grade.
Accompanied with nondestructive test certification of lifting hook randomly.



Wire rope with high-performance

The imported wire rope of high performance with tensile strength up to 2160 N/MM². The surface with galvanized processing for corrosion prevention effectively.
With good flexibility to ensure wear resistance of the wire rope and prolong its service life.



Lifting height limiter

Freely adjustable screw lifting height limiter with high precision, wide adjustment range, safe and reliable.
Multiple-contact configurations can effectively achieve the function of transition with low and high speed and the stop during the rise and fall.

3.2 ~ 20ton

Single Girder Wire Rope Hoist

It has the technical characteristics of light dead weight, low headroom and small wheel pressure.

Ensure the stability and safety of product use.

Create long-term value for customers.

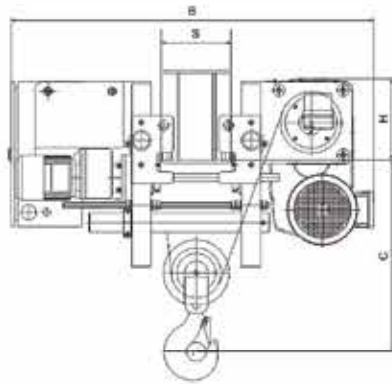
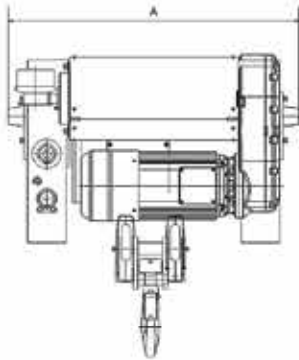

» Technical Parameters

type	Capacity (t)	Lifting height (m)	Work level FEM/ISO	Lifting speed m/min	Lifting power kW	Travelling speed m/min	Travelling power kW	Size H (mm)	Size C (mm)	Size A (mm)	Size B (mm)	Size S (mm)
HKDE-3.2-6S	3.2	6	2m/M5	5/0.8	3.2/0.45	5-20	0.37	244	385	932	1087-1587	200-500
HKDE-3.2-9S	3.2	9	2m/M5	5/0.8	3.2/0.45	5-20	0.37	245	385	1082	1087-1587	200-500
HKDE-3.2-12S	3.2	12	2m/M5	5/0.8	3.2/0.45	5-20	0.37	245	385	1282	1087-1587	200-500
HKDE-3.2-15S	3.2	15	2m/M5	5/0.8	3.2/0.45	5-20	0.37	245	385	1482	1087-1587	200-500
HKDE-3.2-18S	3.2	18	2m/M5	5/0.8	3.2/0.45	5-20	0.37	245	385	1682	1087-1587	200-500
HKDE-5.0-6S	5.0	6	2m/M5	5/0.8	6.1/1	5-20	0.5	268	495	940	1095-1395	200-500
HKDE-5.0-9S	5.0	9	2m/M5	5/0.8	6.1/1	5-20	0.5	266	495	1090	1095-1395	200-500
HKDE-5.0-12S	5.0	12	2m/M5	5/0.8	6.1/1	5-20	0.5	268	495	1290	1095-1395	200-500
HKDE-5.0-15S	5.0	15	2m/M5	5/0.8	6.1/1	5-20	0.5	266	495	1490	1095-1395	200-500
HKDE-5.0-18S	5.0	18	2m/M5	5/0.8	6.1/1	5-20	0.5	268	495	1690	1095-1395	200-500
HKDE-10.0-6S	10.0	6	2m/M5	5/0.8	9.5/1.5	5-20	0.75	296	792	940	1282-1582	200-500
HKDE-10.0-9S	10.0	9	2m/M5	5/0.8	9.5/1.5	5-20	0.75	296	792	1090	1282-1583	200-500
HKDE-10.0-12S	10.0	12	2m/M5	5/0.8	9.5/1.5	5-20	0.75	298	792	1290	1282-1584	200-500
HKDE-10.0-15S	10.0	15	2m/M5	5/0.8	9.5/1.5	5-20	0.75	296	792	1490	1282-1585	200-500
HKDE-10.0-18S	10.0	18	2m/M5	5/0.8	9.5/1.5	5-20	0.75	296	792	1690	1282-1586	200-500
HKDE-12.5-6S	12.5	6	1AM/M4	5/0.8	12.5/2	5-20	0.75	296	792	940	1282-1587	200-500
HKDE-12.5-9S	12.5	9	1AM/M4	5/0.8	12.5/2	5-20	0.75	296	792	1090	1282-1588	200-500
HKDE-12.5-12S	12.5	12	1AM/M4	5/0.8	12.5/2	5-20	0.75	298	792	1290	1282-1589	200-500
HKDE-12.5-15S	12.5	15	1AM/M4	5/0.8	12.5/2	5-20	0.75	296	792	1490	1282-1590	200-500
HKDE-12.5-18S	12.5	18	1AM/M4	5/0.8	12.5/2	5-20	0.75	296	792	1690	1282-1591	200-500
HKDE-16.0-6S	16.0	6	2m/M5	4/0.6	16/2.6	5-20	0.75x2	300	900	1690	1282-1591	200-500
HKDE-16.0-9S	16.0	9	2m/M5	4/0.6	16/2.6	5-20	0.75x2	300	900	1690	1282-1591	200-500
HKDE-16.0-12S	16.0	12	2m/M5	4/0.6	16/2.6	5-20	0.75x2	300	900	1690	1282-1591	200-500
HKDE-16.0-15S	16.0	15	2m/M5	4/0.6	16/2.6	5-20	0.75x2	300	900	1690	1282-1591	200-500
HKDE-16.0-18S	16.0	18	2m/M5	4/0.6	16/2.6	5-20	0.75x2	300	900	1690	1282-1591	200-500
HKDE-20.0-6S	20.0	6	1AM/M4	4/0.6	16/2.6	5-20	0.75x2	300	900	1690	1282-1591	200-500
HKDE-20.0-9S	20.0	9	1AM/M4	4/0.6	16/2.6	5-20	0.75x2	300	900	1690	1282-1591	200-500
HKDE-20.0-12S	20.0	12	1AM/M4	4/0.6	16/2.6	5-20	0.75x2	300	900	1690	1282-1591	200-500
HKDE-20.0-15S	20.0	15	1AM/M4	4/0.6	16/2.6	5-20	0.75x2	300	900	1690	1282-1591	200-500
HKDE-20.0-20S	20.0	18	1AM/M4	4/0.6	16/2.6	5-20	0.75x2	300	900	1690	1282-1591	200-500

Due to continuous product optimization and improvement, if there is any parameter change, the actual shall prevail



3.2 ~ 80ton

Double Girder Wire Rope Hoist

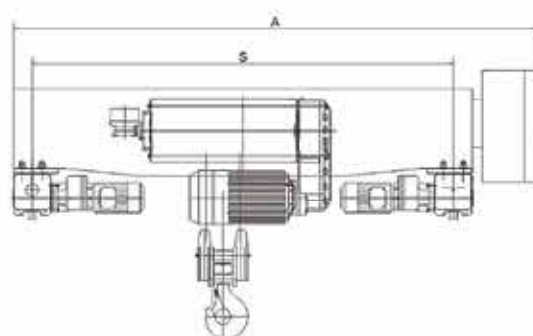
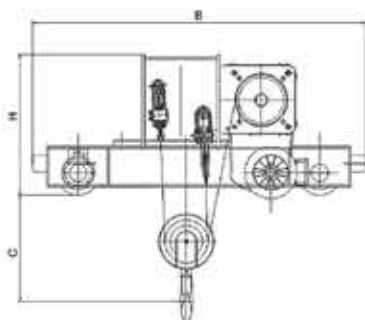

» Technical Parameters

type	Capacity (t)	Lifting height (m)	Work level FEM/ISO	Lifting speed m/min	Lifting power kW	Travelling speed m/min	Travelling power kW	Size H (mm)	Size C (mm)	Size A (mm)	Size B (mm)	Size S (mm)
HKDE-3.2-8D	3.2	6	2m/M5	5/0.8	3.2/0.45	5-20	0.18*2	430	350	1850	1240	1400
HKDE-3.2-9D	3.2	9	2m/M5	5/0.8	3.2/0.45	5-20	0.18*2	430	350	1850	1240	1400
HKDE-3.2-12D	3.2	12	2m/M5	5/0.8	3.2/0.45	5-20	0.18*2	430	350	1850	1240	1400
HKDE-3.2-15D	3.2	15	2m/M5	5/0.8	3.2/0.45	5-20	0.18*2	430	350	2150	1240	1700
HKDE-3.2-18D	3.2	18	2m/M5	5/0.8	3.2/0.45	5-20	0.18*2	430	350	2450	1240	2000
HKDE-5.0-6D	5.0	6	2m/M5	5/0.8	6.1/1	5-20	0.18*2	430	350	1850	1240	1400
HKDE-5.0-9D	5.0	9	2m/M5	5/0.8	6.1/1	5-20	0.18*2	430	350	1850	1240	1400
HKDE-5.0-12D	5.0	12	2m/M5	5/0.8	6.1/1	5-20	0.18*2	430	350	1850	1240	1400
HKDE-5.0-15D	5.0	15	2m/M5	5/0.8	6.1/1	5-20	0.18*2	430	350	2150	1240	1700
HKDE-5.0-18D	5.0	18	2m/M5	5/0.8	6.1/1	5-20	0.18*2	430	350	2450	1240	2000
HKDE-10.0-6D	10.0	6	2m/M5	5/0.8	9.5/1.5	5-20	0.37*2	540	380	1850	1240	1400
HKDE-10.0-9D	10.0	9	2m/M5	5/0.8	9.5/1.5	5-20	0.37*2	540	380	1850	1240	1400
HKDE-10.0-12D	10.0	12	2m/M5	5/0.8	9.5/1.5	5-20	0.37*2	540	380	2150	1240	1700
HKDE-10.0-15D	10.0	15	2m/M5	5/0.8	9.5/1.5	5-20	0.37*2	540	380	2150	1240	1700
HKDE-10.0-18D	10.0	18	2m/M5	5/0.8	9.5/1.5	5-20	0.37*2	540	380	2450	1240	2000
HKDE-12.5-6D	12.5	6	1AM/M4	5/0.8	12.5/2	5-20	0.37*2	540	420	1850	1240	1400
HKDE-12.5-9D	12.5	9	1AM/M4	5/0.8	12.5/2	5-20	0.37*2	540	420	1850	1240	1400
HKDE-12.5-12D	12.5	12	1AM/M4	5/0.8	12.5/2	5-20	0.37*2	540	420	2150	1240	1700
HKDE-12.5-15D	12.5	15	1AM/M4	5/0.8	12.5/2	5-20	0.37*2	540	420	2150	1240	1700
HKDE-12.5-18D	12.5	18	1AM/M4	5/0.8	12.5/2	5-20	0.37*2	540	420	2450	1240	2000

» Technical Parameters

type	Capacity (t)	Lifting height (m)	Work level FEM/ISO	Lifting speed m/min	Lifting power kW	Travelling speed m/min	Travelling power kW	Size H (mm)	Size C (mm)	Size A (mm)	Size B (mm)	Size S (mm)
HKDE-16.0-6D	16.0	6	2m/M5	4/0.6	16/2.6	5-20	0.55*2	640	480	2150	1610	1700
HKDE-16.0-9D	16.0	9	2m/M5	4/0.6	16/2.6	5-20	0.55*2	640	480	2450	1610	2000
HKDE-16.0-12D	16.0	12	2m/M5	4/0.6	16/2.6	5-20	0.55*2	640	480	2850	1610	2400
HKDE-16.0-15D	16.0	15	2m/M5	4/0.6	16/2.6	5-20	0.55*2	640	480	3150	1610	2700
HKDE-16.0-18D	16.0	18	2m/M5	4/0.6	16/2.6	5-20	0.55*2	640	480	3550	1610	3100
HKDE-20.0-6D	20.0	6	1AM/M4	4/0.6	16/2.6	5-20	0.55*2	640	480	2150	1610	1700
HKDE-20.0-9D	20.0	9	1AM/M4	4/0.6	16/2.6	5-20	0.55*2	640	480	2450	1610	2000
HKDE-20.0-12D	20.0	12	1AM/M4	4/0.6	16/2.6	5-20	0.55*2	640	480	2850	1610	2400
HKDE-20.0-15D	20.0	15	1AM/M4	4/0.6	16/2.6	5-20	0.55*2	640	480	3150	1610	2700
HKDE-20.0-18D	20.0	18	1AM/M4	4/0.6	16/2.6	5-20	0.55*2	640	480	3550	1610	3100
HKDE-25.0-6D	25.0	6	2m/M5	3.3/0.8	20/5	5-20	1.1*2	790	620	2450	1850	2000
HKDE-25.0-9D	25.0	9	2m/M5	3.3/0.8	20/5	5-20	1.1*2	790	620	2850	1850	2400
HKDE-25.0-12D	25.0	12	2m/M5	3.3/0.8	20/5	5-20	1.1*2	790	620	3550	1850	3100
HKDE-25.0-15D	25.0	15	2m/M5	3.3/0.8	20/5	5-20	1.1*2	790	620	3650	1850	3100
HKDE-25.0-18D	25.0	18	2m/M5	3.3/0.8	20/5	5-20	1.1*2	790	620	3850	1850	3400
HKDE-32.0-6D	32.0	6	2m/M5	3.3/0.8	20/5	5-20	1.1*2	790	620	2450	1850	2000
HKDE-32.0-9D	32.0	9	2m/M5	3.3/0.8	20/5	5-20	1.1*2	790	620	2850	1850	2400
HKDE-32.0-12D	32.0	12	2m/M5	3.3/0.8	20/5	5-20	1.1*2	790	620	3550	1850	3100
HKDE-32.0-15D	32.0	15	2m/M5	3.3/0.8	20/5	5-20	1.1*2	790	620	3550	1850	3100
HKDE-32.0-18D	32.0	18	2m/M5	3.3/0.8	20/5	5-20	1.1*2	790	620	3850	1850	3400
HKDE-40.0-6D	40.0	6	1AM/M4	0-4.9	38	5-20	1.5*2	895	980	2650	2140	2000
HKDE-40.0-9D	40.0	9	1AM/M4	0-4.9	38	5-20	1.5*2	895	980	2650	2140	2000
HKDE-40.0-12D	40.0	12	1AM/M4	0-4.9	38	5-20	1.5*2	895	980	3050	2140	2400
HKDE-40.0-15D	40.0	15	1AM/M4	0-4.9	38	5-20	1.5*2	895	980	3350	2140	2700
HKDE-40.0-18D	40.0	18	1AM/M4	0-4.9	38	5-20	1.5*2	895	980	3750	2140	3100
HKDE-50.0-6D	50.0	6	2m/M5	0-3.2	38	5-20	1.5*2	895	980	2650	2100	2000
HKDE-50.0-9D	50.0	9	2m/M5	0-3.2	38	5-20	1.5*2	895	980	3050	2100	2400
HKDE-50.0-12D	50.0	12	2m/M5	0-3.2	38	5-20	1.5*2	895	980	3750	2100	3100
HKDE-50.0-15D	50.0	15	2m/M5	0-3.2	38	5-20	1.5*2	895	980	4450	2100	3800
HKDE-50.0-18D	50.0	18	2m/M5	0-3.2	38	5-20	1.5*2	895	980	4850	2100	4200
HKDE-63.0-6D	63.0	6	1AM/M4	0-3.2	38	5-20	2.2*2	975	1110	2700	2220	2000
HKDE-63.0-9D	63.0	9	1AM/M4	0-3.2	38	5-20	2.2*2	975	1110	3100	2220	2400
HKDE-63.0-12D	63.0	12	1AM/M4	0-3.2	38	5-20	2.2*2	975	1110	3800	2220	3100
HKDE-63.0-15D	63.0	15	1AM/M4	0-3.2	38	5-20	2.2*2	975	1110	4500	2220	3800
HKDE-63.0-18D	63.0	18	1AM/M4	0-3.2	38	5-20	2.2*2	975	1110	4900	2220	4200
HKDE-80.0-6D	80.0	6	1AM/M4	0-2.4	38	5-20	2.2*2	975	1110	3100	2220	2400
HKDE-80.0-9D	80.0	9	1AM/M4	0-2.4	38	5-20	2.2*2	975	1110	3800	2220	3100
HKDE-80.0-12D	80.0	12	1AM/M4	0-2.4	38	5-20	2.2*2	975	1110	4500	2220	3800
HKDE-80.0-15D	80.0	15	1AM/M4	0-2.4	38	5-20	2.2*2	975	1110	4900	2220	4200
HKDE-80.0-18D	80.0	18	1AM/M4	0-2.4	38	5-20	2.2*2	975	1110	5500	2220	4800

Due to continuous product optimization and improvement, if there is any parameter change, the actual shall prevail



HKD Goods Hoist

Voltage : 3 Phase 415V 50Hz

Model	Capacity (ton)	Lifting Height (meter)	Lifting Speed (m/min)	Hoisting Motor (Kw)	Rope Size (MM)	Reeving	Duty Rating %
HKDS0202-6M	2	6	8.4	2.9	11.2	2/1	60
HKDS0202-9M		9					
HKDS0202-12M		12					
HKDS0202-18M		18					
HKDS0302-6M	3.2	6	7.5	4.2	14	2/1	60
HKDS0302-9M		9					
HKDS0302-12M		12					
HKDS0302-18M		18					
HKDS0504-6M	5	6	6.7	5.9	12.5	4/3	60
HKDS0504-9M		9					
HKDS0504-12M		12					
HKDS0504-18M		18					

HKD® Wire Rope Fixed Hoist

Designed and Developed for Extreme Application

HKD Wire Rope Hoist represents a revolutionary new generation of exceptionally reliable electric wire rope hoists, featuring advanced technology and cutting-edge performance combines with the latest in manufacturing and materials technology.

It is metric capacity rated, heavy-duty, has higher lifting speeds and precise positioning control demanded by industry world wide. Unique features included low maintenance, sealed brakes, a single or two-speed hoist motor.

Goods only Lift



Maximize staff productivity by eliminating the need to manually carry any goods from one floor level to another, while minimizing massive human efforts and injuries related to manual load handling.

The HKD range of goods hoists is designed to offer the simplest, quickest, most economical and reliable lifting solutions over manual handling. Suitable for :

- Hotels
- Restaurants
- Fast Food Outlets
- Pubs & Clubs
- Hypermarkets & Supermarkets
- Department Stores & Shopping Malls
- Offices
- Showrooms
- Furniture Malls
- Factories
- Warehouses
- Conference Centres

Gearbox

Comprises of a fully enclosed oil-immersed, triple reduction gear train with SNCM21.

Hoist Brake

Single disc, fail safe electromechanical brake, energized separately from the motor, with direct current to ensure a positive action and fitted directly onto the hoist gearbox input shaft.

Dual Braking System

Highly reliable braking system.

The double braking system consists of the main brake and the auxiliary brake unit.

Rope Drum

Precision machined to ensure strength and rugged durability compared to casting. All steel drums are mounted on heavy duty precision ball bearing.

Designed and Develop for Extreme Application

Fall Prevention Devices provides an added measure of stability and safety that cannot be assured with less substantial structural components.

Stopping force automatically exerted equally on both sides of guide rail and full swivel of rail grips provides full and uniform contact on all rail faces when safety is actuated

The safety device is electroplated, antirust, comes with guide shoe and optional lubricant container.

Steel plate body is light weight, easy to set up and holds up to 4,000kgs per unit.

HKD® Fall Prevention Safety Device

Model	Description
HKD-SC-01	Safety Catch
HKD-SC-02	Guide Shoe
HKD-SC-03	Nylon Liner
HKD-SC-04	Lubricant Container
HKD-SC-05	Fall Prevention Safety Device Complete Set

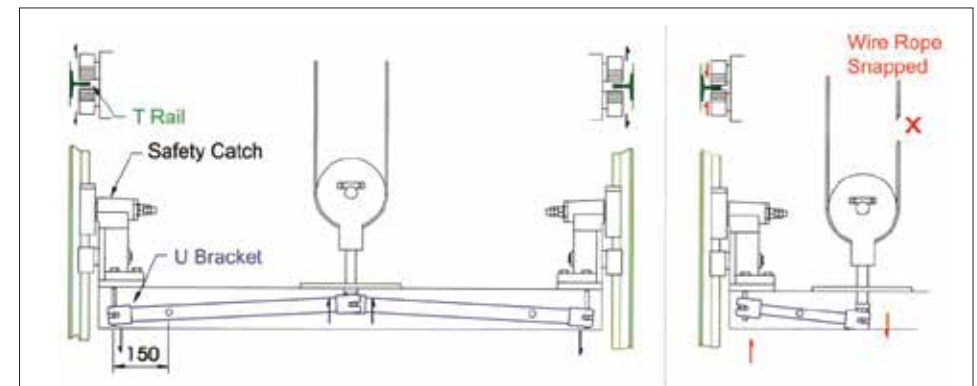

HKD® Goods Lift Accessory

Model	Description
HKD-PLC-101	Standard Control System Complete Set
HKD-PLC-102	2 Floor PLC Control System Complete Set
HKD-PLC-103	3 Floor PLC Control System Complete Set
HKD-PLC-104	4 Floor PLC Control System Complete Set
HKD-PLC-105	5 Floor PLC Control System Complete Set

PLC Control with Floor Display

